



## **VERSATRUK 1500**

**Product Code: LTEPF41150**

The Liftek VersaTruk 1500 Fully Electric Pallet Truck with built-in Lithium-ion battery offers a cost-effective handling solution with maximum flexibility.

### **VERSATRUK 1500 QUICK SPECS :**

**Weight = 120 kg / Capacity = 1500 kg :**

**560 mm x 1150 mm - OTHER FORK SIZES AVAILABLE**

### **KEY FEATURES**

- ✓ **Fully Electric, with Electric Lift and Forwards/Backwards Drive**
- ✓ **Removable Lithium-Ion Battery**
- ✓ **Approx. 5.5hrs Constant Usage w/ Single Battery / 11hrs w/ 2 Batteries**
- ✓ **Only weighs 120kg!**
- ✓ **12 Month Warranty as Standard**

**LI-ION**  
TECHNOLOGY

CALL US TODAY AND TALK TO OUR TEAM OF EXPERTS

**0800 619 0800**

# VERSATRUK 1500

Product Code: LTEPF41150

## Why the VersaTruk 1500?

The VersaTruk 1500 brings maximum flexibility in configurations for every application, from occasional usage to heavy duty. Featuring a two power slot design, VersaTruk offers the option of two 24V/20Ah batteries to maximize runtime for full-time applications. The standard single-battery setting comes with a portable storage container to keep everything easily accessible on the go. Its versatility makes FlexiTruk an all-rounder, perfect for diverse tasks in the most cost effective way.



**Heavy-duty**  
Estimated real life working time: 11hrs



**Occasional usage**  
Estimated real life working time: 5.5hrs



CALL US TODAY AND TALK TO OUR TEAM OF EXPERTS

**0800 619 0800**

# VERSATRUK 1500

Product Code: LTEPF41150



Experts in handling solutions

Distinguishing mark	1.1	Manufacturer			Liftek
	1.2	Model designation			LTEPF41150
	1.3	Drive unit			Electric
	1.4	Operator type			Pedestrian
	1.5	rated capacity	Q	kg	1500
	1.6	Load center distance	c	mm	600
	1.8	Load distance, centre of drive axle to fork	x	mm	950
	1.9	Wheelbase	y	mm	1180
	Service weight	2.1	Service weight		kg
2.2		Axle loading, laden front/rear		kg	480/1140
2.3		Axle loading, unladen front/rear		kg	90/30
Tyres/chassis	3.1	Tyre type			Polyurethane
	3.2	Tyre size, front		mm	210x70
	3.3	Tyre size, rear		mm	Φ80x60( Φ74x88)
	3.4	Additional wheels		mm	Φ74x30 optional
	3.5	Wheels, number front/rear (x=drive wheels)		mm	1x 2/4 (1x 2/2)
	3.6	Tread, front	b10	mm	—
	3.7	Tread, rear	b11	mm	535/410
Dimensions	4.4	Lift height	h3	mm	105
	4.9	Height drawbar in driving position min./max.	h14	mm	750/1190
	4.15	Lowered height	h13	mm	82
	4.19	Overall length	l1	mm	1550
	4.20	Length to face of forks	l2	mm	400
	4.21	Overall width	b1/b2	mm	695/590
	4.22	Fork dimensions	s/e/l	mm	55/150/1150
	4.25	Distance between fork-arms	b5	mm	685/560
	4.32	Ground clearance, center of wheelbase	m2	mm	25
	4.34.1	Aisle width for pallets 1000×1200 crossways	Ast	mm	2160
	4.34.2	Aisle width for pallets 800×1200 crossways	Ast	mm	2025
4.35	turning radius	Wa	mm	1360	
Performance data	5.1	Travel speed, laden/unladen		km/h	4/4.5
	5.2	Lifting speed, laden/unladen		m/s	0.017/0.020
	5.3	Lowering speed, laden/unladen		m/s	0.046/0.058
	5.8	Max. gradeability, laden/unladen		%	5/16
	5.10	Service brake			Electromagnetic
Electric-engine	6.1	Drive motor rating S2 60 min		kW	0.75
	6.2	Lift motor rating at S3 15%		kW	0.5
	6.4	Battery voltage/nominal capacity		V/Ah	24/20
	6.5	Battery weight		kg	5
	Addition data	8.1	Type of drive unit		
10.5		Steering design			Mechanical
10.7		ound pressure level at the driver's ear		dB(A)	<74

If there are improvements of technical parameters or configurations, no further notice will be given. The diagram shown may contain non-standard configurations.

CALL US TODAY AND TALK TO OUR TEAM OF EXPERTS

**0800 619 0800**

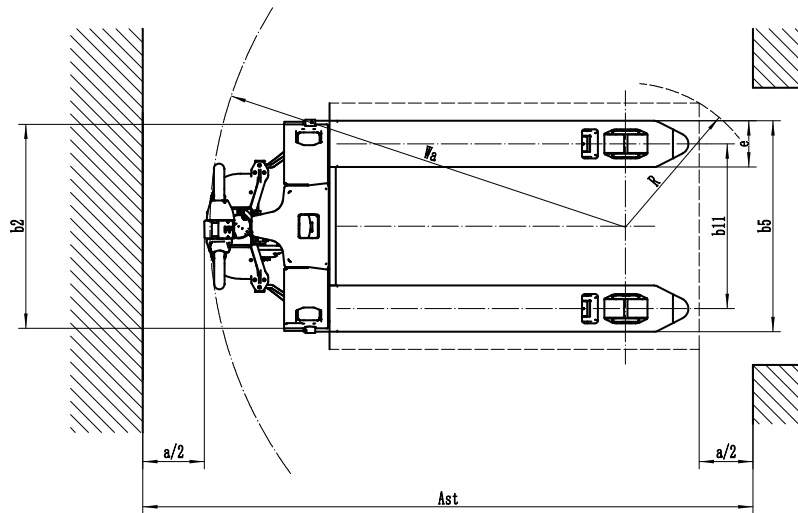
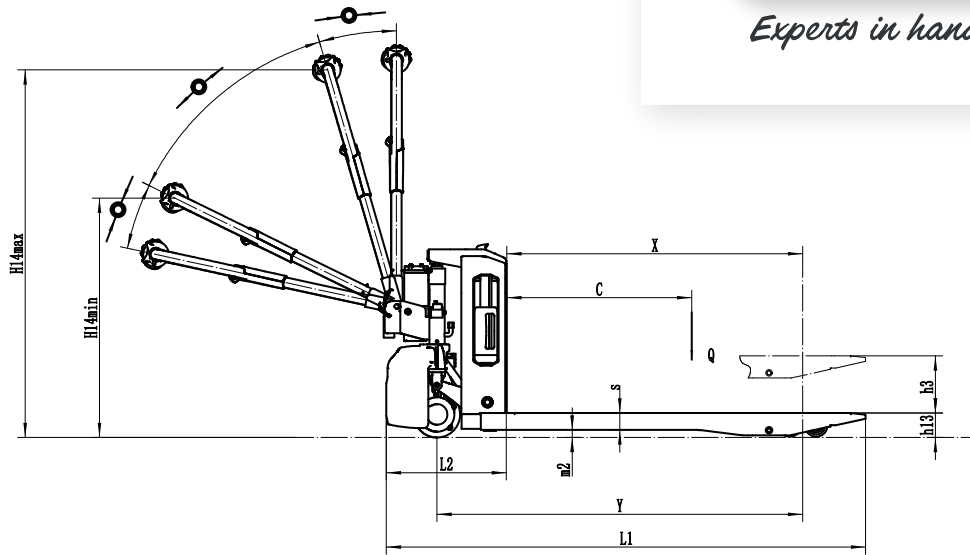

No.	Optional items	F4
1.1	Fork dimension	● 1150*560○900*560○1000*560○1220*560○1350*560○1500*560 ○900*685○1000*685○1150*685○1220*685○1350*685○1500*685
1.3	Fork lowered height	●80
1.6	Drive cover off the ground	●45mm (CE)○65mm (Non CE)
2.1	Load wheel type	●Double○Single
2.2	Load wheel material	●Polyurethane
2.3	Drive wheel material	●Polyurethane
2.7	Battery capacity	●20AH×1 (with a storage container)○20AH×2○20AH×3○20AH×4
2.8	Charger	●24V-4A External○24V-10A External
2.9	Battery indicator	●Without time
2.16	handle head type	●Hands big handle head○Hands small handle head
3.3	Castor wheels	●No○Yes and not customized
3.12	Hummer	●Yes and not customized
3.16	Vertical handler working	●Yes and not customized
4.8	Drive assembly	●Yes and not customized

Note: ●Standard ○ Optional - Inconformity